

FRONT SECTION

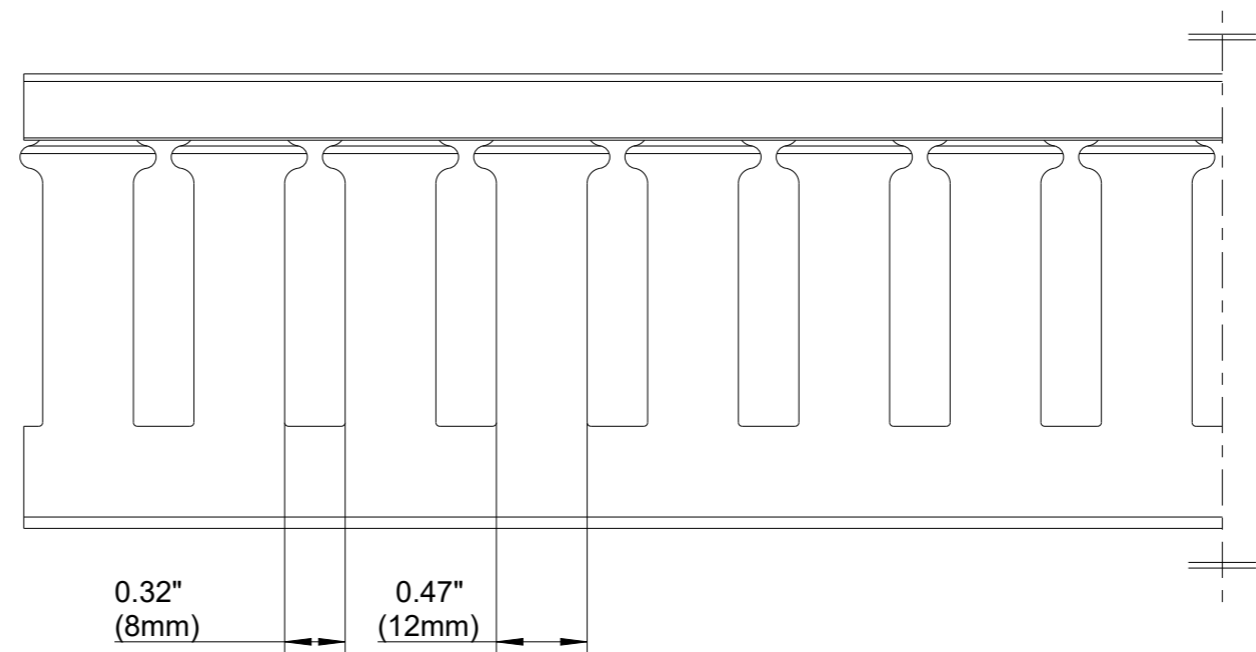

SIDE SECTION

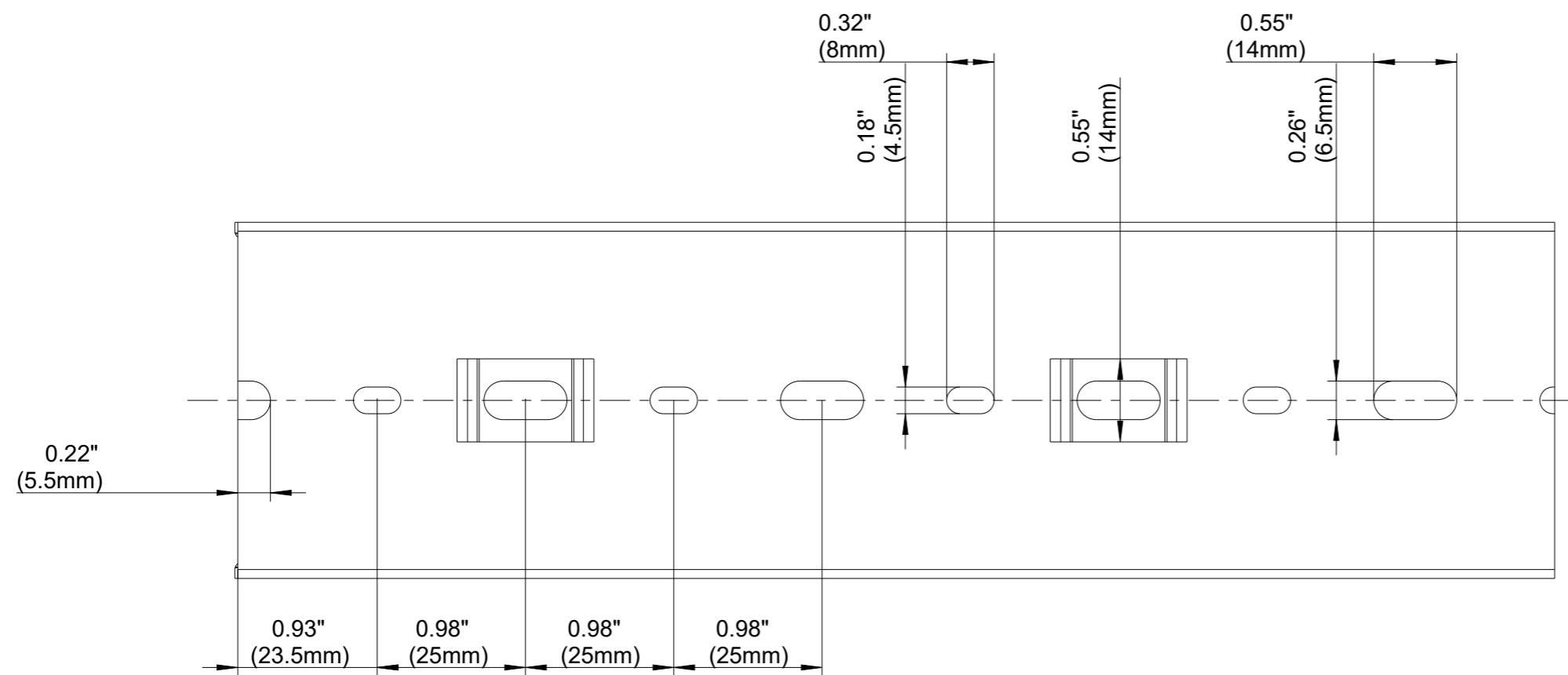

BASE PERFORATION